

The input COM terminal must be connected to 0V

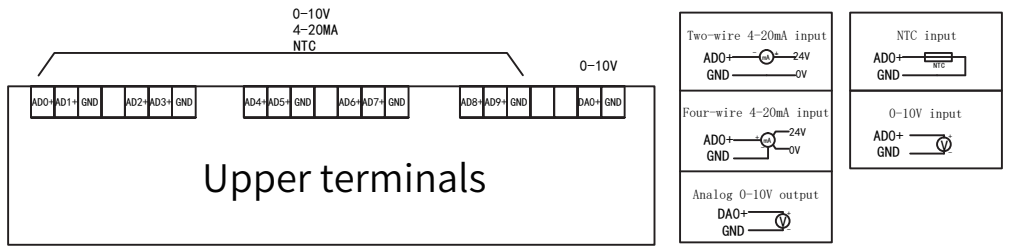

The input COM terminal must be connected to 0V

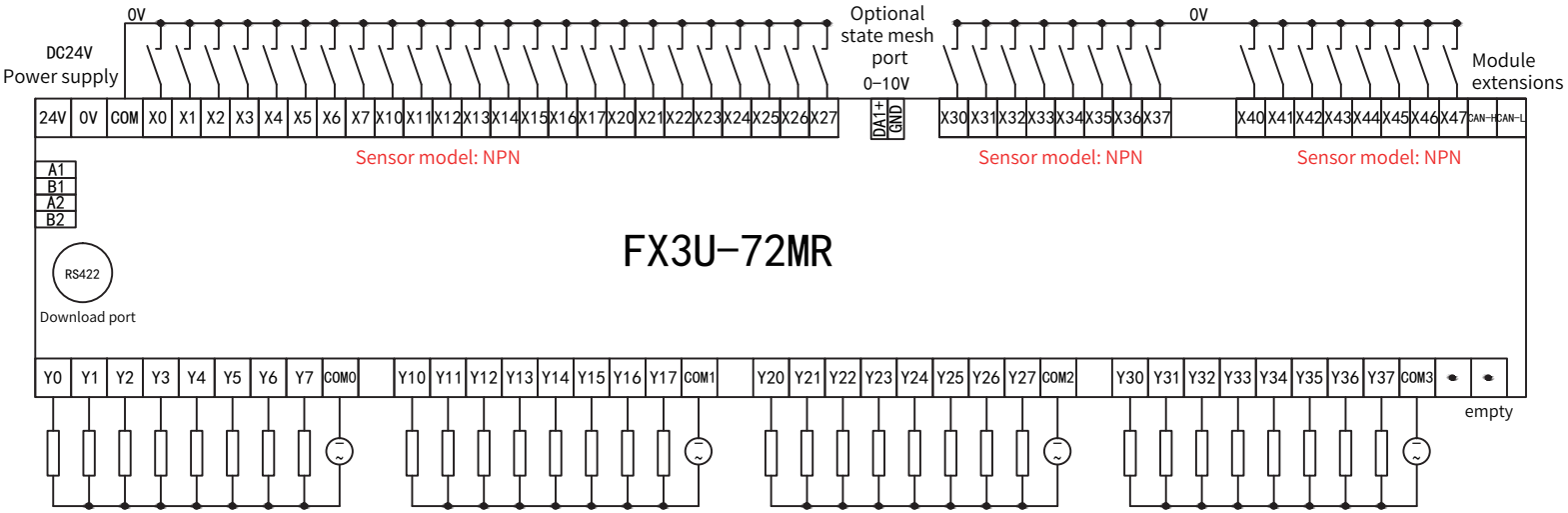
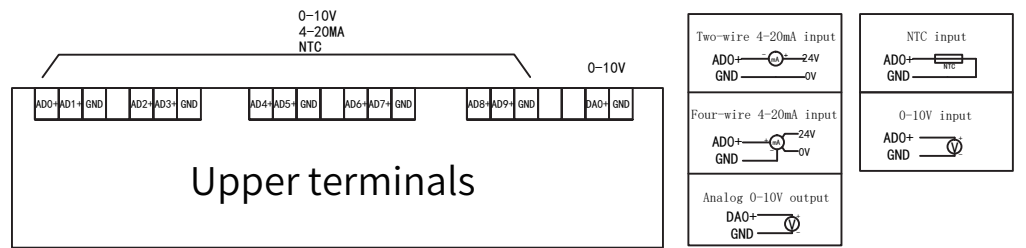
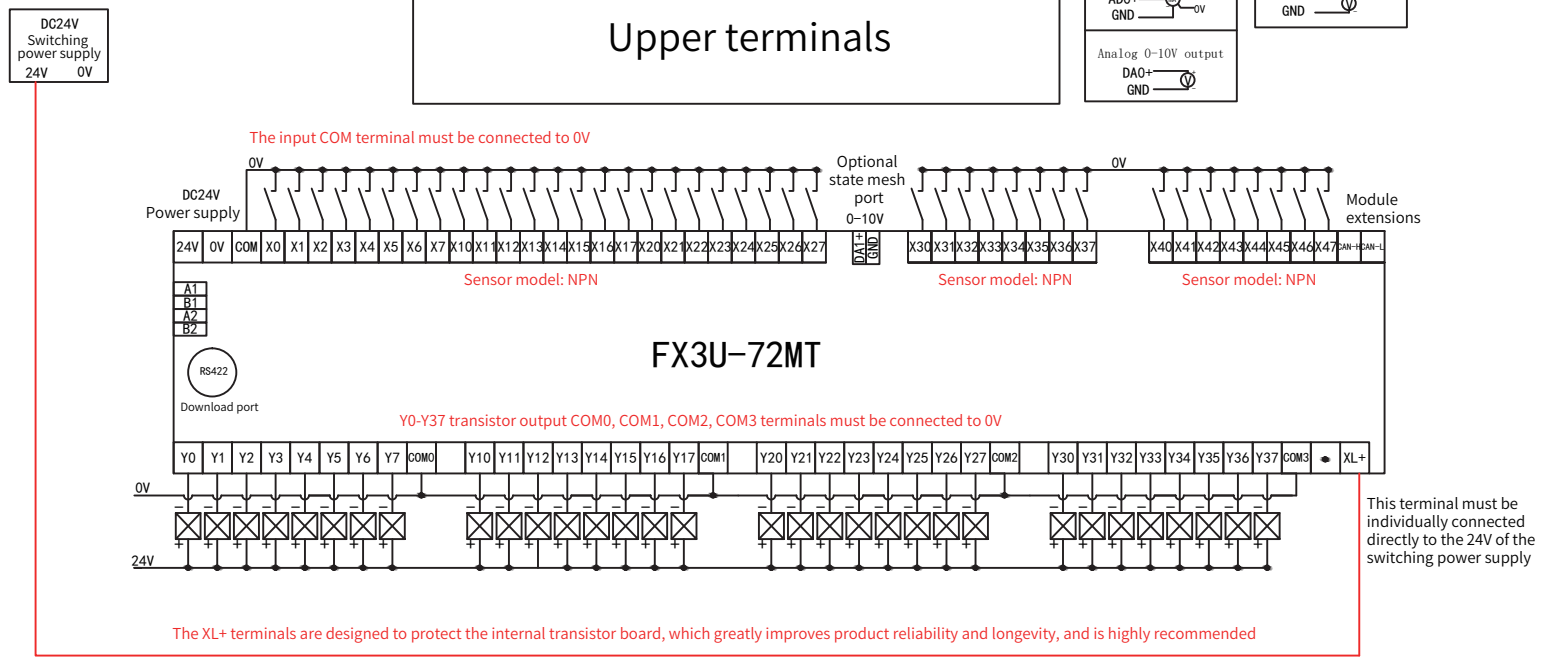

The input COM terminal must be connected to 0V

